

EVI DC Inverter Series R32

Installation Manual **(Carel controller)**

Air to Water Heat Pump

Heating+Cooling+DHW

Refrigerant: R32

PC board code:

LCD code:

1. Attentions



Warning



Caution



Prohibition



This appliance is not intended for use by persons, including children, with reduced physical, sensory or mental capabilities, or lack of experience and knowledge, unless they have been given supervision or instruction concerning use of the appliance by a person responsible for their safety. Children should be supervised to ensure that they do not play with the appliance.

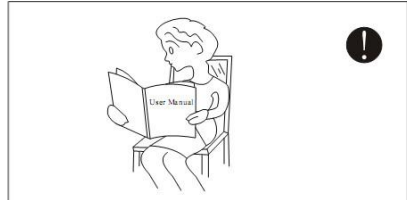

Be sure to read this manual before use.

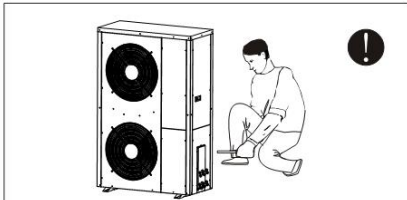

Be sure to read this manual before use. The installation, dismantling and maintenance of the unit must be performed by qualified personnel. It is forbidden to do any changes to the structure of the unit. Otherwise injury of person or unit damage might happen.

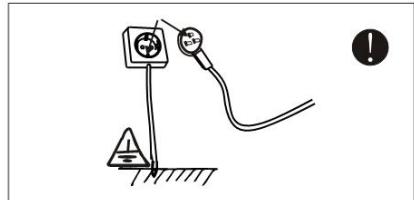

The power supply to the unit must be grounded.

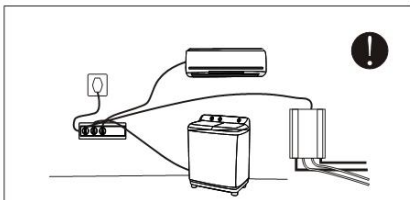

Use a dedicated socket for this unit, otherwise malfunction may occur.



Do not touch the air outlet grill when fan motor is running.

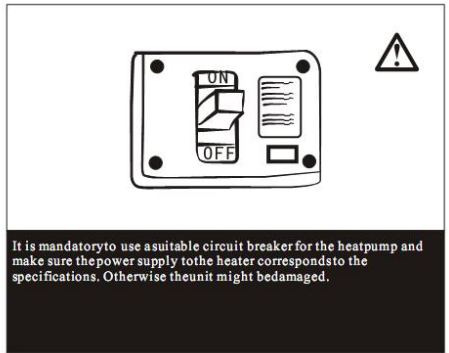
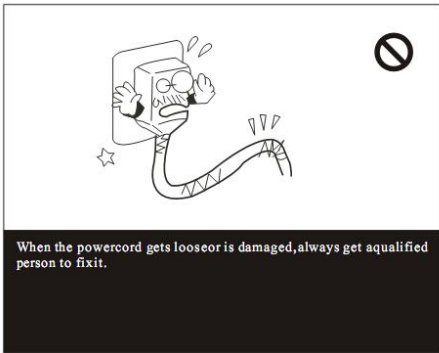
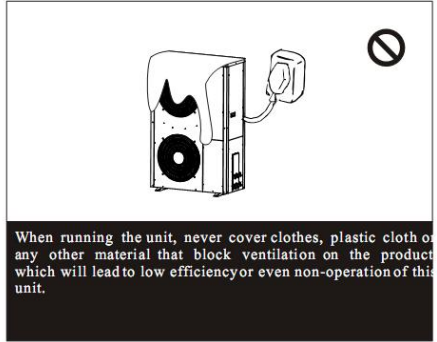
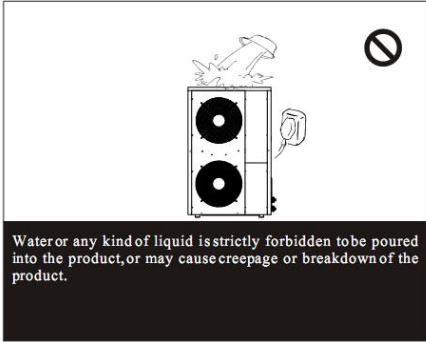

Safety precaution

2. Installation instructions

1. Installation should comply with local regulations and requirements.
2. Choose a suitable space for use (please refer to indoor/outdoor unit location selection). The cooling capacity/heating capacity of the heat pump should be compatible with the size, height, and heat insulation effect of the room.
3. Before installation, be sure to confirm the neutral line, L, N, A phase, B phase, C phase, ground line of the user power supply and the neutral line of the heat pump, L, N, A phase, B phase, C phase, ground One correspondence.
4. This heat pump complies with the safety and operation standards issued by the country.
5. When the heat pump needs to be installed or moved. It must be operated by professional refrigeration installation and maintenance personnel. Heat pumps installed by non-professionals are prone to quality or safety problems.
6. The user should provide a power supply that satisfies the installation and use. The allowable range of voltage that can be used by this product is $\pm 10\%$ of the rated value. If this range is exceeded, it will affect the normal operation of the heat pump. If necessary, use a voltage stabilizer to avoid property damage.
7. The heat pump must have an independent circuit. The independent circuit needs to install a leakage protector and an automatic circuit breaker. Need to be purchased by the user.
8. The heat pump should be installed in accordance with the national wiring regulations.
9. The heat pump must be grounded correctly and reliably, otherwise it may cause electric shock or fire
10. Please do not turn on the power of the heat pump until the piping and wires are connected and carefully checked.

Safety precaution

3.R32 refrigerant introduction

The heat pump uses environmentally friendly R32 refrigerant. This is a slightly flammable refrigerant. Although it can burn and explode under certain conditions, as long as it is installed in a room of the correct area and used correctly, there will be no danger of combustion and explosion. Compared with ordinary refrigerants, R32 is an environmentally friendly refrigerant that does not destroy the ozone layer, and its greenhouse effect value is also very low.

R32 heat pump room area requirements

The area of the heat pump installation, operation and storage room should be larger than 4 square meters.



Warning

1. Please read this manual before installation, operate and maintenance.
2. Except as specifically recommended by the manufacturer, pls do not use any method to speed up the defrosting process or clean the frosted part.
3. Pls do not puncture or ignite the heat pump.
4. The heat pump should be stored in a room without a continuous fire source (such as gas appliances ignited by an open flame, electric heaters, etc.).
5. When repairs are required, please contact the nearest after-sales service center. When repairing, you must strictly abide by the operation manual provided by the manufacturer, and it is forbidden to repair by non-professionals.
6. Pls comply with the relevant national gas laws and regulations.
7. The refrigerant in the system needs to be recovered and removed during maintenance or disposal.



Safety precaution

Repair of sealing elements

1. When repairing closed components, disconnect the power supply to the equipment before opening the sealed cover. If power supply is necessary during the maintenance process, continuous leak detection should be performed on the most dangerous parts to prevent potentially dangerous situations from happening.

2. In the following maintenance of electrical components, special care should be taken not to affect the protection level of the enclosure. Improper maintenance methods may cause: damage to cables, excessive connections, terminals not installed according to the original regulations, damage to the seal, incorrect installation of the sealing cover and other dangers. Ensure that the installation of the equipment is safe and reliable. Ensure that the sealing or sealing material will not lose its function of preventing the entry of flammable gas due to aging. Replacement parts should meet the manufacturer's specifications.

Note: The use of silicon-containing sealants may reduce the detection capabilities of leak detection equipment. Intrinsically safe components do not need to be isolated before operation.

Maintenance of intrinsically safe components

If it is not possible to ensure that the heat pump does not exceed the allowable voltage and current limits during use, do not use any permanent inductive or capacitive load in the circuit.

Intrinsically safe components are the only components that can continue to work in flammable gases. The test instrument should be set in the correct gear.

The replacement components can be only used the parts specified by the manufacturer, other parts may cause the refrigerant leaking in the air to catch fire.

Cable

Check whether the cable will be affected by wear, corrosion, overpressure, vibration, sharp edges or other adverse environments. The inspection should also consider the influence of aging or continuous vibration of the compressor and fan on the cable.

Leak inspection of R32 refrigerant

Check for refrigerant leakage should be done in an environment where there is no potential ignition source. Halogen probes (or any other detectors that use open flames) should not be used for detection

Safety precaution

Leak detection method

For systems containing R32 refrigerant, an electronic leak detector can be used for testing. The test should be calibrated in a refrigerant-free environment to ensure that the leak detector does not become a potential source of ignition and is suitable for the refrigerant being tested. The leak detector should be set to the lowest flammable concentration of the refrigerant (expressed as a percentage), calibrated with the refrigerant used and adjusted to the appropriate gas concentration test range (up to 25%).

The fluid used to detect leaks is suitable for most refrigerants, but do not use chlorine-containing solvents to prevent chlorine and refrigerants from reacting and corroding copper pipes.

If a leak is suspected, all open flames should be removed from the scene or the fire should be extinguished.

If welding is required at the location where the leakage occurs, all refrigerants should be recovered, or all refrigerants should be isolated away from the leakage point (use shut-off valves). Oxygen-free nitrogen (OFN) is used to purify the entire system before and during welding.

Remove and vacuum

Maintenance or other operations on the refrigeration circuit should be performed in accordance with normal procedures. However, the safety should also be considered, and the following procedures should be followed:

1. Remove refrigerant;
2. Purify the pipeline with inert gas;
3. Vacuum;
4. Purify the pipeline with inert gas again;
5. Cut the pipe or weld it.

The refrigerant should be recycled into a suitable storage tank. The system should be purged with oxygen-free nitrogen. This process may need to be repeated several times. Do not use compressed air or oxygen for this operation.

In the purging process, the system is filled with oxygen-free nitrogen to reach the working pressure under the vacuum state of the system, and then the oxygen-free nitrogen is discharged into the atmosphere, and finally the system is evacuated. Repeat this process until all refrigerant in the system is removed. After filling the oxygen-free nitrogen for the last time, exhaust the gas to atmospheric pressure, and then the system can be welded. The above operations are necessary for pipeline welding operations.

Ensure that there is no ignition source near the outlet of the vacuum pump and good ventilation.

Safety precaution

Procedure of refrigerant filling

As a supplement for the conventional procedures, the following requirements have been added:

1. Ensure that when using equipment of refrigerant filling, there will not be the mutual contamination between different refrigerants. The pipeline of refrigerant filling should be as short as possible to reduce the residual amount of refrigerant;
2. When filling refrigerant, there should be without the fire source near the unit;
3. Make sure that the refrigerant system has taken grounding measures before charging the refrigerant;
4. After filling refrigerant (or not finished), stick the label on the system;
5. Must be careful not excessive filling;

Perform a pressure test with oxygen-free nitrogen before refilling refrigerant into the system. After filling, a leak test must be carried out before the trial operation. The leak test must be carried out again when leaving the area.

Scrapping

Before proceeding with this procedure, the technician should be fully familiar with the equipment and all of its characteristics. It is recommended to recover safe refrigerant. If it is necessary to re-use the recovered refrigerant, samples of refrigerant and oil should be analyzed before operation. Before testing, please ensure that you have got the required power source.

Being familiar with the equipment and its operation;

2. Disconnecting the power supply;
3. Before proceeding with this procedure making sure that:

If necessary, the equipment of mechanical operation should be convenient to operate the refrigerant storage tank;

All personal protective equipment are effective and can be used correctly;

The entire recycling process should be carried out under the guidance of qualified persons; Recycling equipment and refrigerant storage tanks should meet the corresponding standards.

Maintenance safety matters

Warning

1. For repairs or scrapping, please contact the nearest or authorized service center.
2. Repairs performed by unqualified personnel may be dangerous.
3. When charging the heat pump with R32 refrigerant and maintaining it, please strictly observe the manufacturer's requirements. This chapter mainly focuses on the special maintenance requirements of R32 refrigeration appliances. Please refer to the after-sales service manual for

Safety precaution

detailed maintenance operations.

Qualification requirements for maintenance personnel

1. All operating personnel or refrigeration circuit maintenance personnel should obtain a valid certificate issued by an industry-recognized evaluation agency to determine that they have the qualifications for safe handling of refrigerants as required by the industry-recognized evaluation specifications.
2. The maintenance and repair of the equipment can only be carried out in accordance with the method recommended by the equipment manufacturer. If other professionals are required to assist in maintaining and repairing the equipment, it should be carried out under the supervision of personnel qualified to use flammable refrigerants.

Site inspection

Before repairing heat pumps using R32 refrigerant, safety inspections must be carried out to ensure that the risk of fire is minimized. When servicing the refrigeration system, the following precautions should be observed before handling the system.

Operational procedure

Operations should be carried out under a controlled procedure to ensure that the risk from combustible gases or vapors is minimal during operations.

General operating area

All maintenance people and other people in the operation area should be aware of the character of the operation being performed. Avoid working in confined Spaces. Work areas should be properly isolated to ensure safe working conditions within the work area by controlling combustible materials.

Check whether the refrigerant is present

Refrigerant monitors are necessary to be used in the area before and during operations to ensure that technicians are aware of the presence of potentially combustible gases. Ensure that the leak detection equipment used is suitable for R32 refrigerants, such as sparkless, fully sealed, or intrinsically safe.

Placement of fire extinguishers

The applicable fire extinguisher should be located close to the cooling system or related components during hot working operations. The refrigerant injection area should be equipped with dry powder or carbon dioxide fire extinguisher.

No fire

Any fire sources should not be used when performing work related to exposed pipes that hold or have held R32 refrigerant which may cause a fire or explosion hazard. All sources of fire,

Safety precaution

including smoking, should be kept away from the area of installation, repair, removal and disposal of combustible refrigerants that may release into the surrounding environment. Before starting operations, check the environment around the equipment to ensure that there is no danger of flammability or fire. There should be a "no smoking" sign.

Ventilated area

Ensure that the work area is open or fully ventilated before opening the system or performing thermal processing operations. Keep ventilation during operation. Ventilation will safely dilute the leaked refrigerant and quickly discharge it into the atmosphere.

Inspection of refrigeration equipment

If the electrical components are replaced, these electrical components should be installed in accordance with the purpose of use and correct operation regulations. At all times, you should follow the manufacturer's maintenance and repair guidelines. If you have any questions, please consult the manufacturer's technical department. For installations using R32 refrigerant heat pumps, the following inspection items apply:

1. The filling amount should be determined according to the marked amount on the heat pump's rating plate.
2. The ventilation equipment should operate normally, and the vents should be unobstructed.
3. If an indirect refrigeration cycle is used, please check whether there is refrigerant in the secondary circuit.
4. The logo or marking on the heat pump should be clearly visible, and the ambiguous signs and symbols should be corrected;
5. Refrigeration piping or electrical components should not be installed in an environment that contains components that may be corrosive to contact the refrigerant, unless the electrical components themselves are made of anti-corrosion materials or take appropriate anti-corrosion measures.



- a. To avoid electrical shock, make sure to disconnect power supply 1 minute or more before operating the electrical part. Even after 1 minute, always measure the voltage at the terminals of main circuit capacitors or electrical parts and, before touching, make sure that those voltages are lower than the safety voltage.
- b. Power supply wire line size must be selected according to this manual. And must be grounded.
- c. Don't put in hands or stick to air outlet grill when fan motor are working.

Safety precaution

- d. Don't use wet hand touch wire lines, and don't pull any wire lines of the unit.
- e. Water or any other kind liquid is forbidden to poured into the unit.
- f. Select correct air breaker and leakage protection switch.
- g. Don't touch the fin of source side heat exchanger, it may hurt your finger.
- h. If any wire line is loose or damaged, suggest let qualified person to fix i

Important parts in heat pump

4.Heat pump installation and wiring

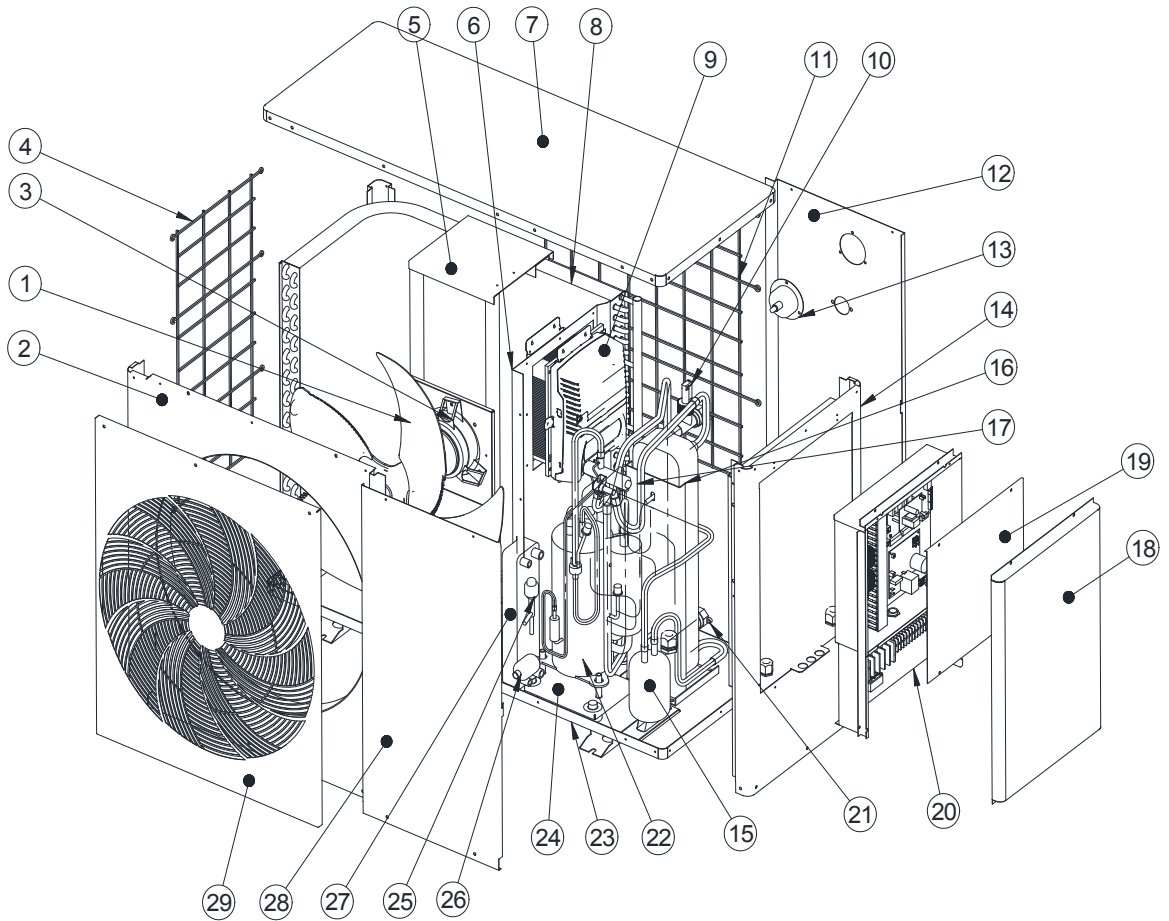

CGK025V3L、CGK-025V3L、CGK030V3L、CGK-030V3L、CGK040V3L、CGK-040V3L

No.	Component	No.	Component
1	Wind leafd	16	Plate heat exchanger (condenser)
2	Air outlet plate	17	Four way valve
3	Fan motor	18	Electric box cover plate
4	Side wire mesh	19	Cover plate of internal electric box
5	Fan support	20	Electric control panel
6	Middle diaphragm	21	Inlet and outlet pipe connection
7	Cover	22	Compressor
8	Evaporator	23	Chassis
9	Frequency converter	24	Damping plate
10	Water flow switch	25	Electronic expansion valve
11	Rear wire mesh	26	Copper filter
12	Rear service panel	27	Plate heat exchanger (economizer)
13	Pressure gauge	28	Front service panel
14	Right side panel	29	Air outlet network
15	Reservoir		

Important parts in heat pump

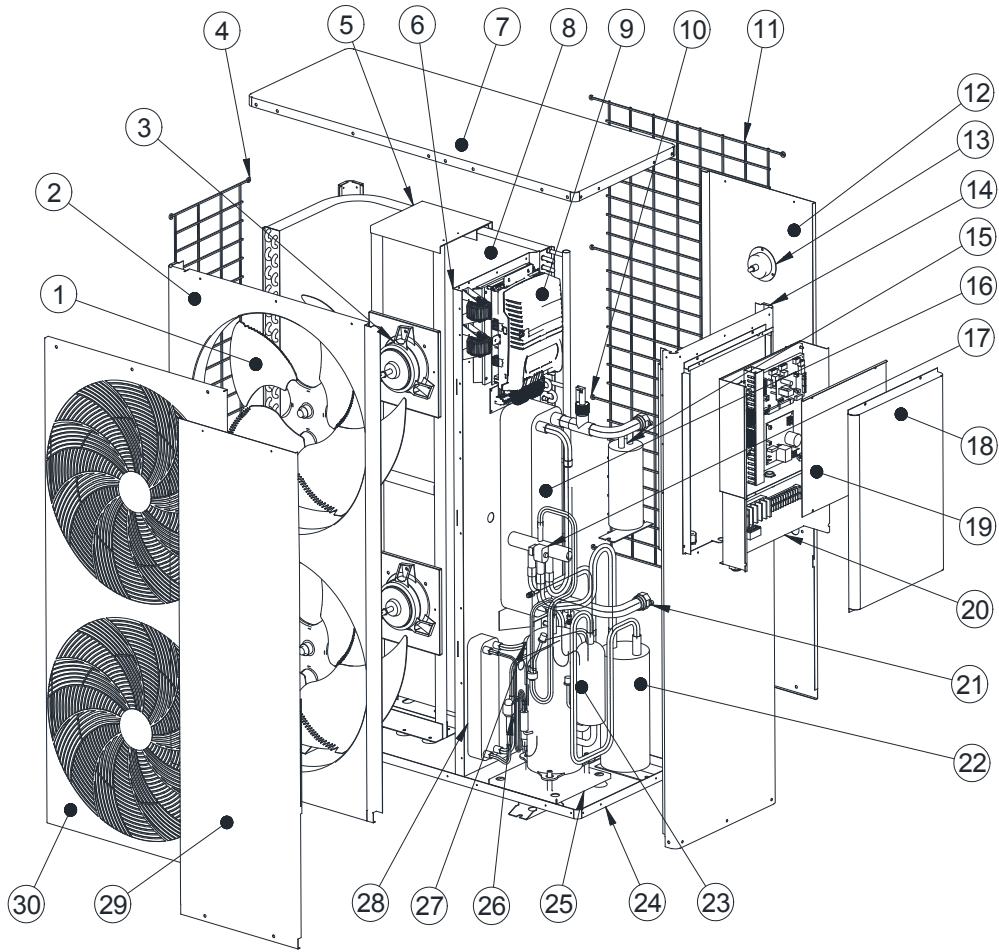

CGK050V3L、CGK-050V3L、CGK060V3L、CGK060V3L

No.	Component	No.	Component
1	Wind leafd	16	Plate heat exchanger (condenser)
2	Air outlet plate	17	Four way valve
3	Fan motor	18	Electric box cover plate
4	Side wire mesh	19	Cover plate of internal electric box
5	Fan support	20	Electric control panel
6	Middle diaphragm	21	Inlet and outlet pipe connection
7	Cover	22	separator
8	Evaporator	23	Compressor
9	Frequency converter	24	Chassis
10	Water flow switch	25	Damping plate
11	Rear wire mesh	26	Electronic expansion valve
12	Rear service panel	27	Copper filter
13	Pressure gauge	28	Plate heat exchanger (economizer)
14	Right side panel	29	Front service panel
15	Reservoir	30	Air outlet network

Heat pump size

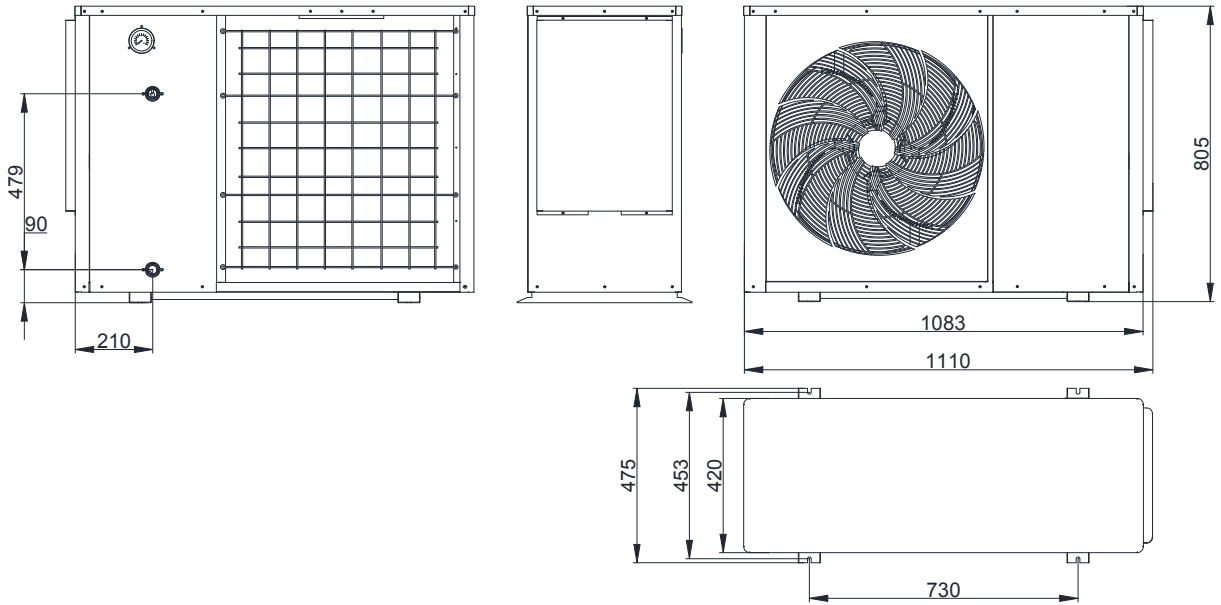

CGK025V3、CGK-025V3、GK030V3L、CGK-030V3L

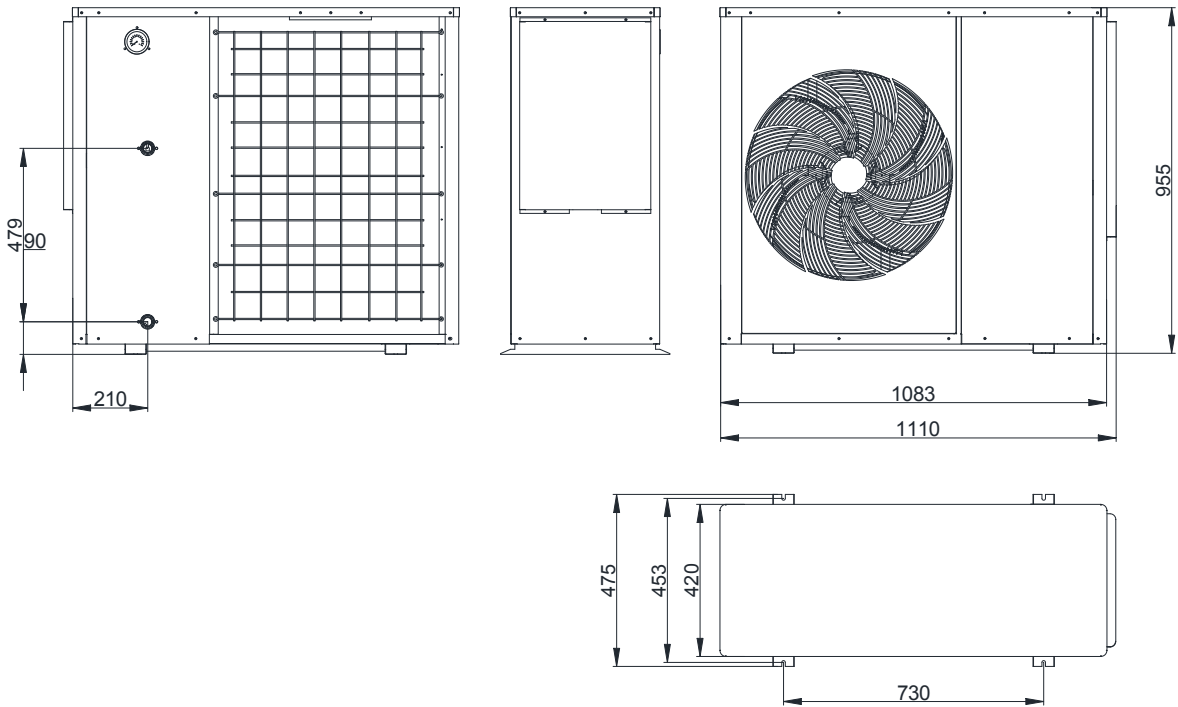

CGK040V3、CGK-040V3

Heat pump size

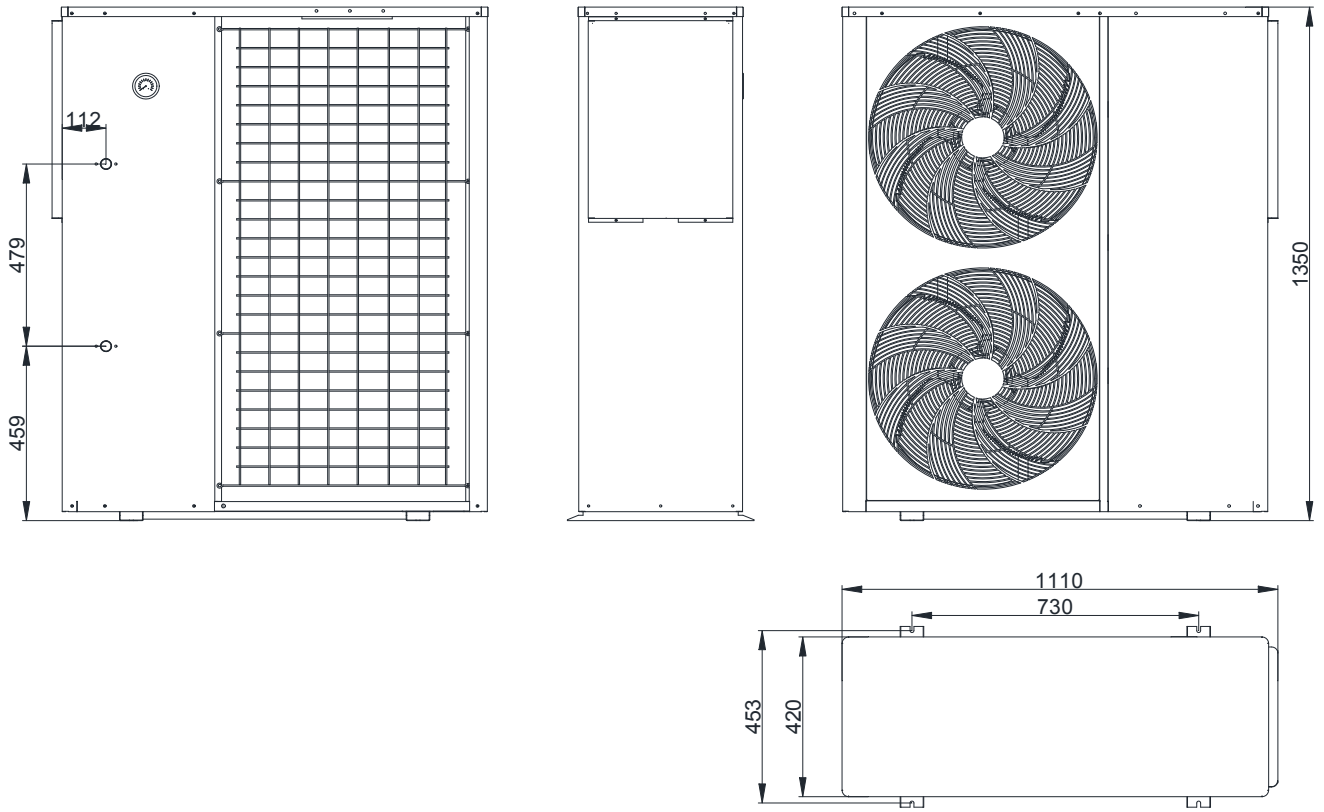









CGK050V3L、CGK-050V3L、CGK060V3L、CGK-060V3L

Installation diagram

Primary circulation system

Notice:

1. Pls select the right modes according to your demand then install it according to the installation diagram. If only hot water function required, pls select heating+hot water mode , and then put the hot water sensor into the hot water tank.
2. Fan coil can be controlled by linkage with the secondary circulation pump . Meanwhile, a passive linkage thermostat shall be installed.
3. This is primary circulation system, If you not need to control the temperature by different zone, you can use this system.

Symbol	Name
	3-way valve
	2-way valve
	Ball valve
	Non-return valve
	Filter
	Water pump
	Temp sensor
	Release valve
	Expansion tank

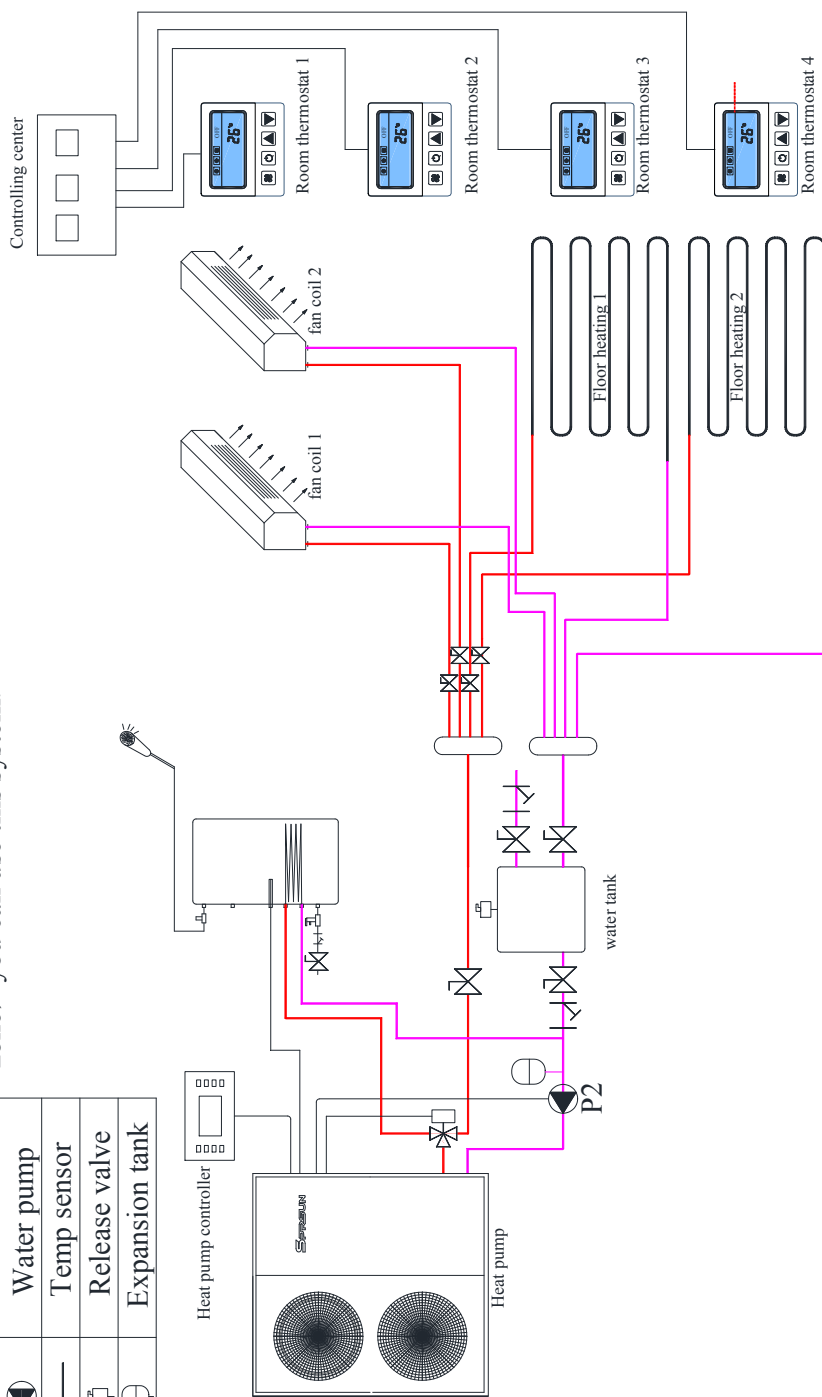

SPRSUN DC inverter air source heat pump

Installation diagram

Secondary circulation system

Notice:

1. Pls select the right modes according to your demand then install it according to the installation diagram. If only hot water function required, pls select heating+hot water mode , and then put the hot water sensor into the hot water tank.
2. Two-way valve and BV valve are optional for installation. Only If you need to control the temperature by different zone, then pls install both.
3. Fan coil can be controlled by linkage with the secondary circulation pump . Meanwhile, a passive linkage thermostat shall be installed.

Symbol	Name
	3-way valve
	2-way valve
	Ball valve
	Non-return valve
	Filter
	Water pump
	Temp sensor
	Release valve
	Expansion tank

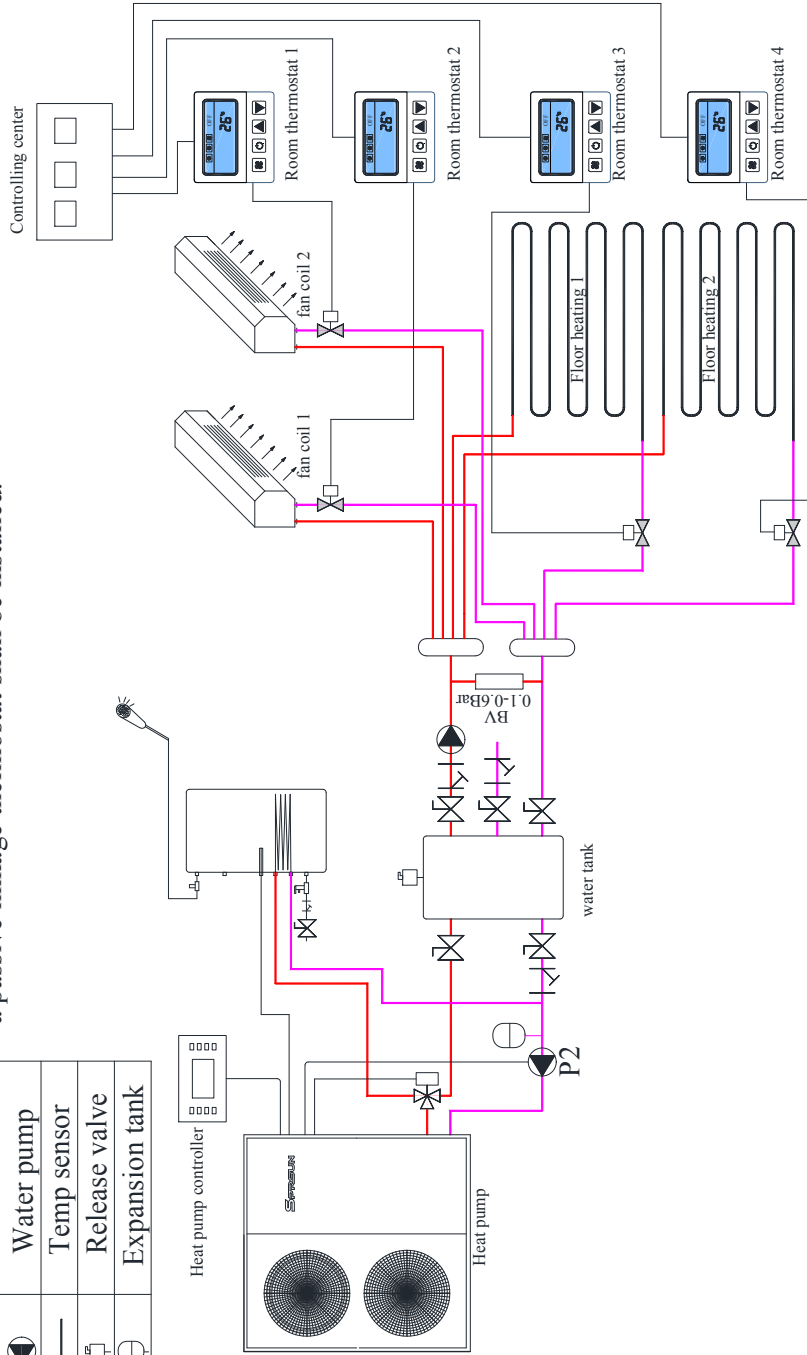

SPRSUN DC inverter air source heat pump

Heat pump installation notes

- 1) The heat pump must be installed in open space. Normally is installed on the roof of house.
- 2) The unit should be placed in dry and well-ventilated environment. If the environment is humid, electronic components may get corroded or short circuit.
- 3) Heat pump mustn't be installed in the environment where corrosive, volatile, or flammable liquid or gas exists.
- 4) Because of the noise is a little loud, please don't install the heat pump near bedroom or living room or meeting room.
- 5) The bottom of the heat pump should be at least 200mm higher than ground, because rain water, snow may enter inside if the installation is on ground. Heat pump can be installed on concrete basic or steel support.
- 6) Please install a shed for the heat pump, otherwise, rain water can reduce the lifetime of the shell, and snow may cover the air outlet.
- 7) Water drainage ditch should be set around the heat pump, when heat pump is working, there is condensing water flow down, or when defrosting, there are plenty of water flow down too.
- 8) Heat pump should far away from kitchen exhaust, because the finned tube is not easy to clean if there is oil on it.

Distances to barrier and ground

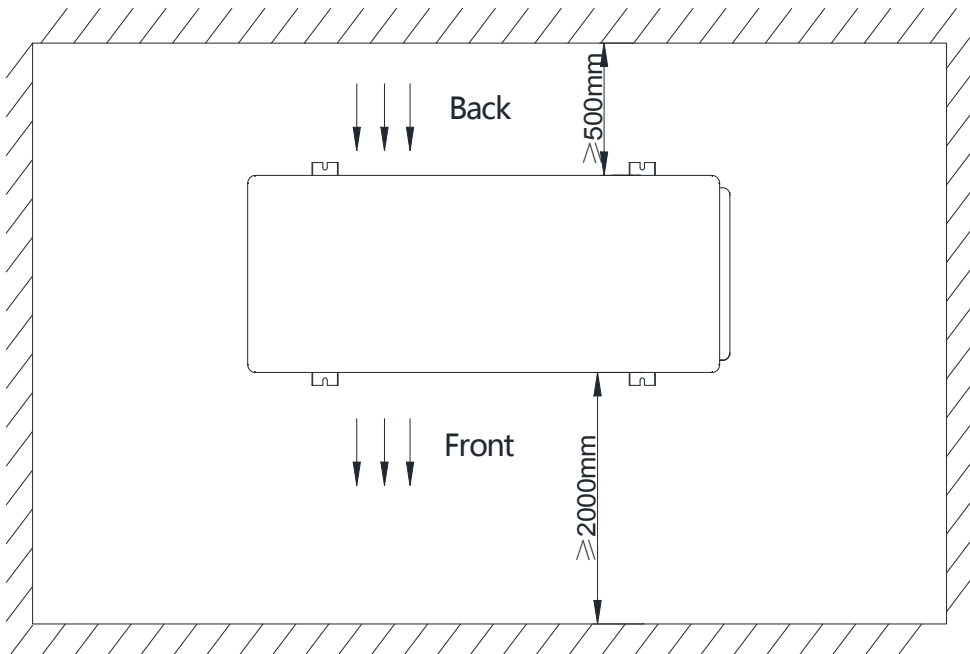
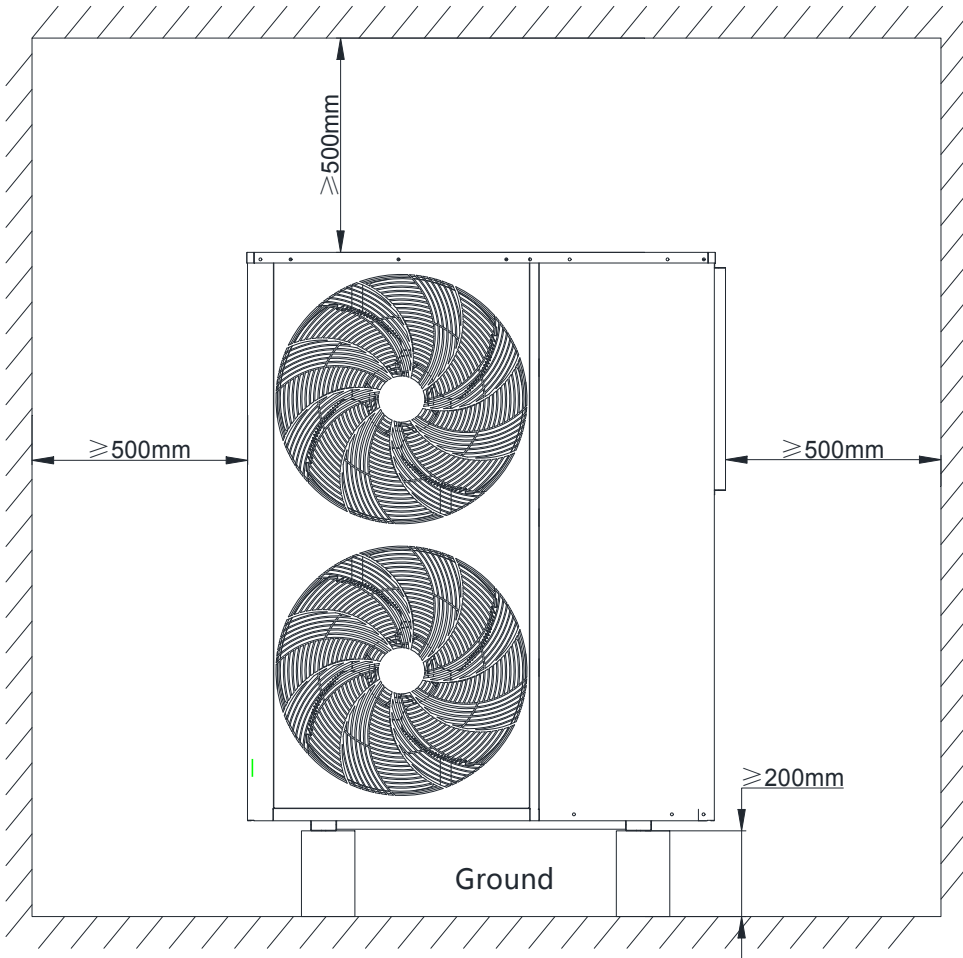

Basic of installation

- 1) Heat pump must be installed on flat concrete blocks or a raised concrete platform, or steel bracket.
- 2) Between heat pump and basic or bracket, at least 4 pcs anti-shock pads should be placed



Concrete basic

Anti-shock pad



Steel bracket



Expansion bolt

- 3) Before make basic or bracket, please check heat pump dimension
- 4) Before fix heat pump on basic, please confirm heat pump direction according to project design.
- 5) Normally use expansion bolt to fix heat pump on concrete basic.
- 6) Make sure circulating water pipe must be \geq DN25 (or PPR32), and pipes must be insulated.
- 7) When install water temp sensor on pipe or in water tank, make sure temp sensor will not touch water directly, best through a sensor tube. Like below picture.

Wiring diagram

220V

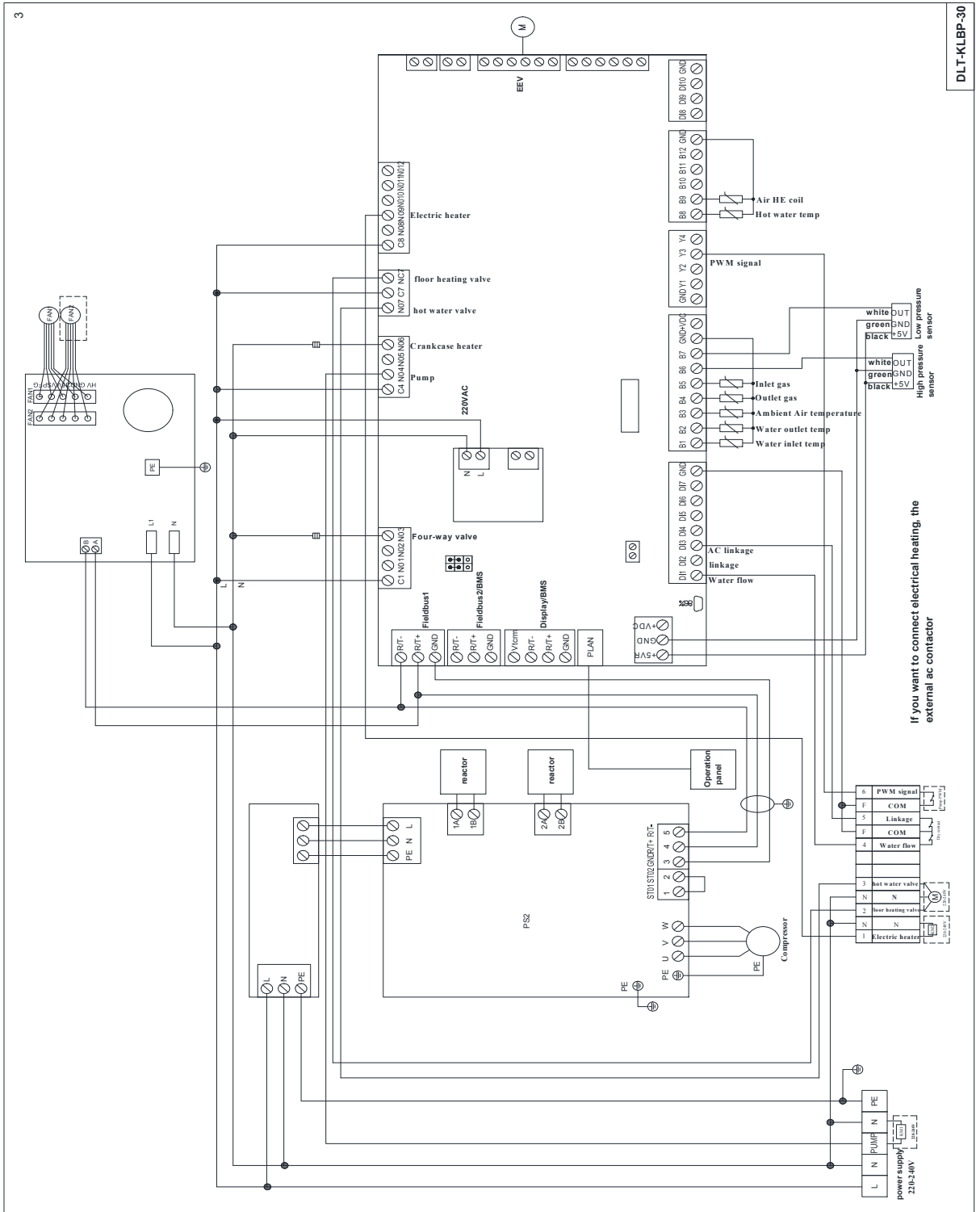

Wiring diagram

380V

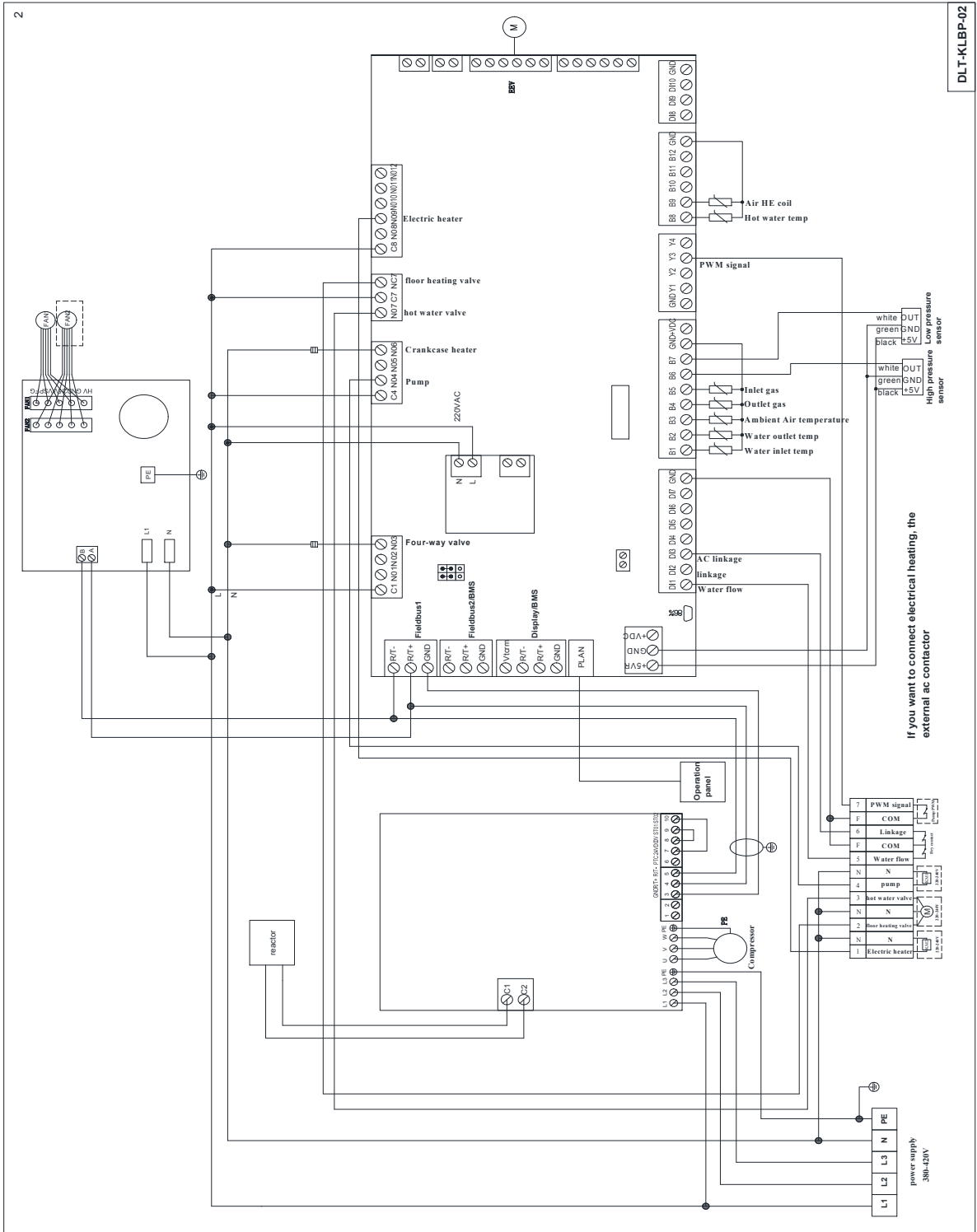

Voltage: 380V ~ 420V/50Hz or 60 Hz/3Ph

Terminals

380V

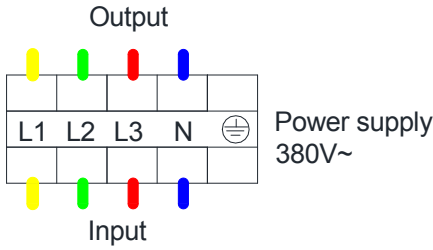

Model	Line(mm ²)	Max. Current(A)
CGK-025V3L	2.5	6.3
CGK-030V3L	2.5	8.3
CGK-040V3L	2.5	10.4
CGK-050V3L	4	12.9
CGK-060V3L	4	14.5

220V

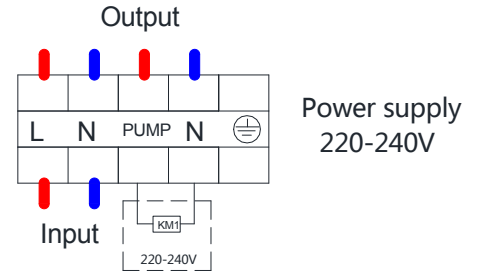

Model	Line(mm ²)	Max. Current(A)
CGK025V3L	4	14.4
CGK030V3L	4	18.7
CGK040V3L	4	23.6
CGK050V3L	6	29.2
CGK060V3L	6	33.0

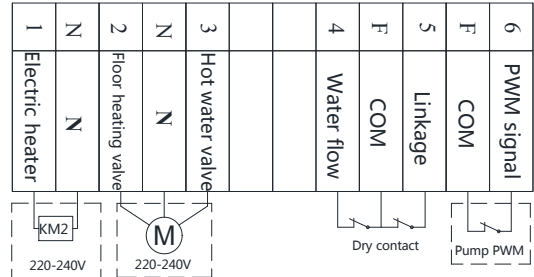
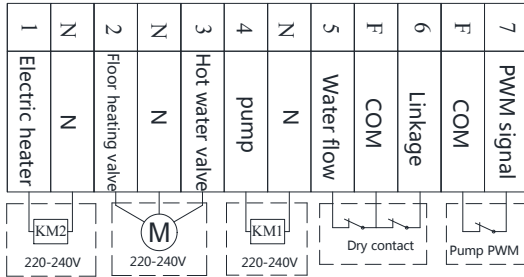

Warning

Air-water heat pump

1. Y-shape filter must be installed in front of water pump.
2. Water flow of cycle water pump for each 0.75kw(input power) $>1\text{m}^3/\text{h}$
3. Pump lift according to job site.
A quarter bend water resistance ≥ 1 meters
4. Domestic hot water utilize national standards urban tap water.
5. Water sensor can't touch water directly, it must be put into the blind hole in water tank .
6. Installation must comply with above conditions, if non-compliance with any one, we do not afford any loss.
7. When air temperature is below 0C , please drain water in heat exchanger if blackout ,to avoid water ice up.
8. A 40-70 mesh filter needs to be added to the water path before entering the heat pump, and the water ion concentration must be less than 280 ppm.